

Duration: 2 hrs

1. The steady state error of a feedback control system with an acceleration input becomes finite in a
 - (a) type 0 system
 - (b) type 1 system
 - (c) type 2 system
 - (d) type 3 system
2. The impulse response of a LTI system is a unit step function, then the corresponding transfer function is
 - (a) $1/s$
 - (b) $1/s^2$
 - (c) 1
 - (d) s
3. For a type one system, the steady state error due to step input is equal to
 - (a) Infinity
 - (b) zero
 - (c) 0.25
 - (d) 0.5
4. The equation $2s^4+s^3+3s^2+5s+10 = 0$ has
 - (a) one
 - (b) two
 - (c) three
 - (d) four roots in the left half of s-plane.
5. If the Nyquist plot of the loop transfer function $G(s)H(s)$ of a closed loop system encloses the $(-1,j0)$ point in the $G(s)H(s)$ plane, the gain margin of the system is
 - (a) zero
 - (b) greater than zero
 - (c) less than zero
 - (d) infinity
6. Given a unity feedback control system with $G(s) = \frac{K}{s(s+4)}$ the value of K for a damping ratio of 0.5 is
 - (a) 1
 - (b) 16
 - (c) 32
 - (d) 64
7. The LVDT is primarily used for the measurement of
 - (a) displacement
 - (b) velocity
 - (c) acceleration
 - (d) humidity
8. A system with gain margin close to unity or a phase margin close to zero is
 - (a) Highly stable
 - (b) oscillatory
 - (c) relatively stable
 - (d) unstable
9. The input to a controller is
 - (a) sensed signal
 - (b) desired variable value
 - (c) error signal
 - (d) servo signal
10. If the transfer function of a first order system is $G(s) = \frac{10}{1+2s}$, then the time constant of the system is
 - (a) 10 seconds
 - (b) 1/10 seconds
 - (c) 2 seconds
 - (d) $\frac{1}{2}$ second

11. An electrometer amplifier has high input impedance of
- a) 1010? b) 105?
c) 1020? d) 1015?
12. When the input of differential amplifier $V_1 = 0$, then the differential amplifier is said to be operated in
- a) Common mode b) Differential mode
c) Non inverting mode d) Inverting mode
13. When either one of the inputs to the differential amplifier is equal to zero then it is said to be operated in
- a) Single ended mode b) Differential mode
c) Non inverting mode d) Inverting mode
14. The negative feedback in an amplifier
- a) Reduces voltage gain b) Increases the voltage gain
c) Increases the gain band width product d) Reduces the input impedances
15. Feedback in an amplifier always helps in
- a) Increasing its input impedance b) Increasing its gain
c) Controlling its output d) Stabilizes its gain
16. Using mechanical chopper we cannot achieve high chopping rates due to their
- a) Input impedance b) Output impedance
c) Response time d) Inertia
17. The CMRR of a typical IC OPAMP is
- a) 70 dB b) 80 dB
c) 85 dB d) 75 dB
18. A _____ is usually a display device used to produce a paper record of analog wave form.
- a) Graphic pen recorder b) Electron microscope
c) X-Y recorder d) Oscilloscope
19. The _____ of a recording system is the magnitude of input voltage required to produce a standard deflection in a recorded trace.
- a) Accuracy b) Linearity
c) Sensitivity d) Resolution
20. A recorder is said to have good frequency response when the sensitivity of the system is _____ for all frequencies present in the signal.
- a) Unity b) Zero
c) Infinity d) Constant

21. A series dissipative regulator is an example of a:
- a. linear regulator
 - b. switching regulator
 - c. shunt regulator
 - d. dc-to-dc converter
22. Which of the following is a unit of mass in the metric system?
- a. gram
 - b. millilitre
 - c. centimetre
 - d. pounds
23. What device is similar to an RTD but has a negative temperature coefficient?
- a. Strain gauge
 - b. Thermistor
 - c. Negative-type RTD
 - d. Thermocouple
24. The resistive change of a strain gauge
- a. is based on the weight placed upon it, but can be many thousands of ohms
 - b. is usually no more than 100 ohms.
 - c. is based on the gauge factor, but is typically less than an ohm
 - d. has a positive temperature coefficient
25. The output voltage of a typical thermocouple is
- a. Less than 100 mV
 - b. Greater than 1 V
 - c. Thermocouples vary resistance, not voltage.
 - d. None of the above
26. The connections to a thermocouple
- a. Can produce an unwanted thermocouple effect, b) Produce an extra desirable thermocouple effect which must be compensated for
 - c. Must be protected, since high voltages are present
 - d. Produce an extra desirable thermocouple effect and must be protected, since high voltages are present
27. What is the zero-voltage switch used for?
- a. To reduce radiation of high frequencies during turn on of a high current to a load
 - b. To control low-voltage circuits
 - c. To provide power to a circuit when power is lost
 - d. For extremely low-voltage applications
28. Temperature sensing can be achieved by the use of
- a. Thermocouples
 - b. RTDs
 - c. Thermistors
 - d. All of the above
29. The purpose of compensation for a thermocouple is
- a. to decrease temperature sensitivity
 - b. to increase voltage output
 - c. to cancel unwanted voltage output of a thermocouple
 - d. used for high-temperature circuits
30. The change in value of an analog signal during the conversion process produces what is called the
- a. Quantization error
 - b. Resolution error
 - c. Nyquist error
 - d. Sampling error

31. Resistively generated inference arises through incorrect _____
- a) Grounding b) Current density at the electrodes
c) Supply voltage d) Input impedance
32. CMRR is more in _____
- a) Single ended amplifier b) Differential amplifier
c) Inverting operational amplifier d) Chopper amplifier
33. For biomedical applications the mostly used amplifier is
- a) Single ended amplifier b) Differential amplifier
c) Inverting operational amplifier d) Chopper amplifier
34. _____ amplifier is used to drive the recorder.
- a) Power amplifier b) Pre amplifier
c) Operational amplifier d) Differential amplifier
35. When a number of components are fabricated on same IC chip it is necessary to provide isolation between two different components for input interconnection is called _____
- a) Input amplification b) Input differentiation
c) Common mode rejection d) Input isolation
36. A chopper amplifier
- a) Converts AC signal from low frequency to high frequency b) Converts DC signal from low frequency to high frequency
c) Converts AC signal from low frequency to DC high frequency d) Converts DC signal from low frequency to high frequency
37. Power amplifier is provided with S1: Cross over distortion compensation S2: Offset control
- a) S1 is true & S2 is false b) S2 is true & S1 is false
c) Both S1 & S2 are true d) Both S1 & S2 are false
38. Pre amplifier isolation in ECG circuit is to
- a) Increase input impedance b) Decrease input impedance
c) Increase output impedance d) Decrease output impedance
39. Raising input impedance of pre amplifier reduces
- a) Input current b) Output current
c) Stray current d) Grid current
40. Common mode rejection ratio is defined as ratio of
- a) Common mode gain to differential mode gain b) Differential mode gain to common mode gain
c) Common mode gain at input to differential mode gain at input d) Common mode gain at output to differential mode gain at output

51. Two voltmeters are each 0-300 V range. Their internal resistances are 10 k Ω and 20 k Ω . They are connected in series and a voltage of 400 V is applied. Their readings respectively will be
- 266.6 and 133.3 V
 - 133.3 and 266.6 V
 - 200 V each
 - 100 and 300 V
52. The current passing through a resistance of $100 \pm 0.2\% \Omega$ is $2 \pm 0.5\% \text{ A}$. The limiting error in computation of power will be
- $\pm 0.7\%$
 - $\pm 0.9\%$
 - $\pm 1.2\%$
 - $\pm 0.3\%$
53. Consider the following instruments
- Tangent galvanometer
 - Rayleigh current balance
 - Household energy meter
 - Hot wire ammeter
- Out of above absolute instruments are
- 1, 2 and 3
 - 1, 2 and 4
 - 1 and 2
 - 2, 3 and 4
54. A 0-150 voltmeter has a guaranteed accuracy of 1% of full scale reading. If actual reading is 83 V, the percentage error is
- 0.83%
 - 1%
 - 1.81%
 - none of the above
55. A wire strain gauge has a gauge factor of 2, resistance of 125 Ω and length 1 m. If length of wire changes by .005 m, change in resistance will be
- 0.25 Ω
 - 0.5 Ω
 - 1.25 Ω
 - 2.5 Ω
56. The dead zone in a pyrometer is 0.125% of span. The calibration is 400°C to 1000°C. What temperature change might occur before it is detected.
- 0.125°C
 - 0.75°C
 - 0.4°C
 - 1°C
57. The ac bridge in figure is balanced. $Z_1 = 100 \angle 30^\circ$, $Z_2 = 150 \angle 0^\circ$, $Z_3 = 250 \angle -40^\circ$. Then $Z_4 =$

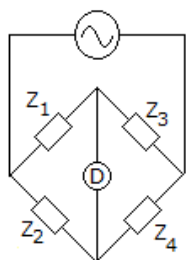

- $375 \angle 70^\circ \Omega$
 - $375 \angle -70^\circ \Omega$
 - $150 \angle 0^\circ \Omega$
 - $150 \angle 20^\circ \Omega$
58. An accelerometer has a seismic mass of 0.05 kg and spring constant of $3 \times 10^5 \text{ N/m}$. If maximum displacement of mass is $\pm 1 \text{ mm}$, the maximum acceleration which can be measured is
- 30 m/s^2
 - 60 m/s^2
 - 90 m/s^2
 - 120 m/s^2
59. PCM employing 4 bit code is used to send data having frequency range from 0 to 2 kHz. The minimum required bandwidth of carrier channel is
- 2 kHz
 - 4 kHz
 - 8 kHz
 - 16 kHz
60. When a capacitor is connected to the terminals of an ohmmeter, the pointer indicated a low resistance initially and finally come to infinity position. This shows that capacitor is
- short circuited
 - all right
 - faulty
 - open circuited

61. The following waveform pattern is for a(n) _____.

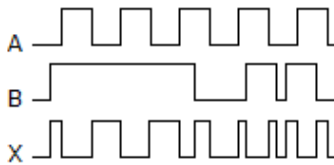

- a 2-input AND gate b 2-input OR gate
c Exclusive-OR gate d None of the above

62. Why, in most applications, are transistor switches used in place of relays?

- a They consume less power. b They are faster.
c They are quieter and smaller. d all of the above

63. A comparator is an example of a(n)

- a. active filter b. current source
c. linear circuit d. nonlinear circuit

64. The coil of a moving iron instrument has a resistance of 500Ω and an inductance of 1 H . It reads 250 V when a 250 V dc is applied. If series resistance is 2000Ω , its reading when fed by 250 V , 50 Hz ac will be

- a 260 V b 252 V
c 250 V d 248 V

65. An ammeter of $0\text{-}25 \text{ A}$ range has a guaranteed accuracy of 1% of full scale reading. The current measured is 5 A . The limiting error is

- a 2% b 2.5%
c 4% d 5%

66. Which of the following voltmeters would you use for measuring voltage across $20 \text{ k}\Omega$ resistance?

- a Voltmeter having a resistance of $5 \text{ k}\Omega$ b Voltmeter having a sensitivity of 1 kW/V
c Voltmeter having sensitivity of 10 kW/V d None of the above

67. A moving coil instrument has a resistance of 0.6Ω and full scale deflection at 0.1 A . To convert it into an ammeter of $0\text{-}15 \text{ A}$ range, the resistance of shunt should be

- a. 0.6Ω b 0.06Ω
c. 0.1Ω d 0.004Ω

68. An LVDT is used to measure displacement. The LVDT feeds a Voltmeter of $0\text{-}5 \text{ V}$ range through a 250 gain amplifier. For a displacement 0.5 mm the output of LVDT is 2 mV . The sensitivity of instrument is

- a. 0.1 V/mm b 0.5 V/mm
c 1 V/mm d. 5 V/mm

69. The Lissajous pattern observed on screen of CRO is a straight line inclined at 45° to x axis. If X-plate input is $2 \sin \omega t$, the Y-plate input is

- A. $2 \sin \omega t$ B. $2 \sin (\omega t + 45^\circ)$
C. $2 \sin (\omega t - 45^\circ)$ D. $22 \sin \omega t + 45^\circ$

70. A meter with a resistance of 100Ω and a full scale deflection of current of 1 mA is to be converted into voltmeter of $0 - 5 \text{ V}$ range. The multiplier resistance should be

- a 490Ω b 5000Ω
c 4900Ω d. 5100Ω

71. An 8085 microprocessor based system uses a 4K x8 bit RAM whose starting address is AA00H. The address of the last byte in this RAM is
- 0FFFH
 - 1000H
 - B9FFH
 - BA00H
72. In an 8085 microprocessor system with memory mapped I/O,
- I/O devices have 16 bit addresses
 - I/O devices are accessed using IN and OUT instructions
 - There can be a maximum of 256 input devices and 256 output devices
 - Arithmetic and logic operations can be directly performed with the I/O data
73. An I/O processor control the flow of information between
- Cache memory and I/O devices
 - Main memory and I/O devices
 - Two I/O devices
 - Cache and main memory
74. If $CS = A_{15}'A_{14}A_{13}$ is used as the chip select logic of a 4K RAM in an 8085 system, then its memory range will be
- 3000 – 3FFFFH
 - 7000 – 7FFFFH
 - 5000 – 5FFFFH and 6000 – 6FFFFH
 - 6000 – 6FFFFH and 7000 – 7FFFFH
75. Which of the following can be used as a tachogenerator in control systems?
- Microsyn
 - DC servomotor
 - AC servomotor
 - Magnetic amplifier
76. Six sets of electromagnetic waves are given below :
 30 - 300 KHz 10 - 30 KHz 3 - 30 MHz 300 - 3000 KHz 30 - 300 MHz > 300 MHz
 They are designated in the following order
- VLF, LF, MF, HF, VHF, UHF
 - LF, VLF, MF, HF, VHF, UHF
 - LF, VLF, HF, MF, VHF, UHF
 - VHF, VLF, HF, MF, LF, UHF
77. Which among the following waveforms can be reconstructed from its samples without distortion?

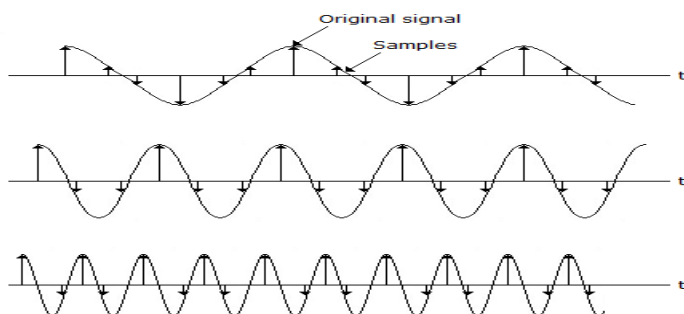

- 1 and 2
 - 2 and 3
 - 1 and 3
 - Only 2
78. Assign the proper odd parity bit to the code 111001.
- 1111011
 - 11111001
 - 0111111
 - 0011111
79. Before an SOP implementation, the expression $X = AB(\bar{C}D + EF)$ would require a total of how many gates?
- 1
 - 2
 - 4
 - 5
80. A 4-variable AND-OR-Invert circuit produces a 0 at its Y output. Which combination of inputs is correct?
- $\bar{A}\bar{B} + \bar{C}D$
 - $\bar{A}\bar{B} + \bar{C}\bar{D}$
 - $\bar{A}\bar{B} + CD$
 - none of the above

88. The amplifier circuit shown below uses a silicon transistor. The capacitors C_C and C_E can be assumed to be short at signal frequency and the effect of output resistance r_o can be ignored. If C_E is disconnected from the circuit, which one of the following statements is TRUE?

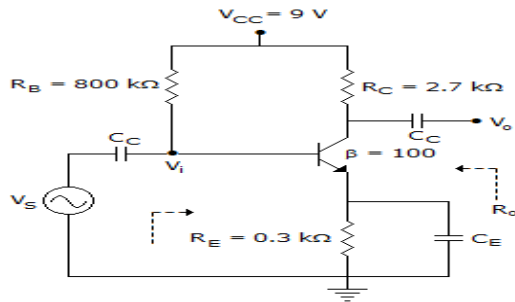

- A. The input resistance R_i increases and the magnitude of voltage gain A_v decreases
 B. The input resistance R_i decreases and the magnitude of voltage gain A_v decreases
 C. Both input resistance R_i and the magnitude of voltage gain A_v decrease
 D. Both input resistance R_i and the magnitude of voltage gain A_v increase
89. The electric field of 2.5×10^7 V/m can give 1 eV energy to condition electron, then in a copper block what will be the mean free path of electron?
- a 5×10^{-8} m b 4×10^{-7} m
 c 0.4 m d 0.5 m
90. The number of hardware interrupts (which require an external signal to interrupt) present in an 8085 microprocessor are
- a. 1 b. 4
 c. 5 d. 13
91. NMOS devices have _____ switching speeds and _____ on-state resistance; as compared with PMOS devices.
- a. slower, higher b. faster, lower
 c. faster, higher d. slower, lower
92. 4 point DFT for $x(n) = \{2, -1, 2, 3\}$ is
- a. $\{6, 4 - 2j, 2, 2\}$ b. $\{6, 4j, 2, -4\}$
 c. $\{6, -1 + 3j, 4 - 4j, 4 - 2\}$ d. $\{6, 2j, 4 - 2j, -2 + 2j\}$
93. $84_{16} - 2A_{16}$ is equal to
- a. $5A_{16}$ b. $4A_{16}$
 c. $7A_{16}$ d. $15A_{16}$
94. A fair coin is tossed independently four times. The probability of the event "the number of time heads shown up is more than the number of times tails shown up" is
- a. $\frac{1}{16}$ b. $\frac{1}{8}$
 c. $\frac{1}{4}$ d. $\frac{5}{16}$
95. The probability density function of a random variable x is as shown

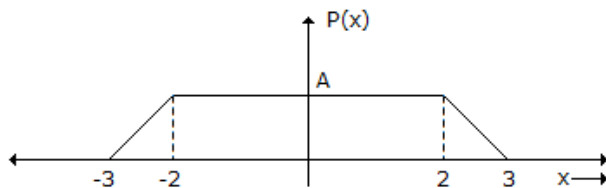

The value of A is:

- a. $\frac{1}{3}$ b. $\frac{1}{4}$
 c. $\frac{1}{5}$ d. $\frac{1}{6}$

96. The logic realized by the circuit shown in figure below is

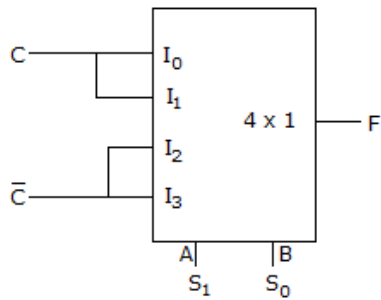

- a. $F = A - C$. b. $F = A \oplus C$.
 c. $F = B \odot C$. d. $F = B \oplus C$

97. The z-transform of a signal $x[n] = 7\left(\frac{1}{3}\right)^n u[n] - 6\left(\frac{1}{2}\right)^n u[n]$ converges if and only if

- a. $\left|\frac{1}{3z}\right| < 1$ and $\left|\frac{1}{2z}\right| < 1$ b. $\left|\frac{1}{3z}\right| < 1$ and $\left|\frac{1}{2z}\right| < 1$
 c. $\left|\left[\frac{1}{3} z^{-1}\right]\right| > 1$ and $\left|\frac{1}{2} z^{-1}\right| > 1$ d. $\left|\frac{1}{3z}\right| > 1$ and $\left|\frac{1}{2z}\right| > 1$

98. The network is as shown below.

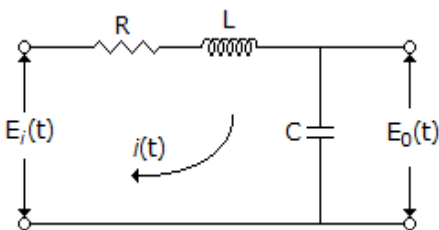

- a. First order system and the pole $-\frac{R}{2L} \pm \sqrt{\left(\frac{R}{2L}\right)^2 - \left(\frac{1}{\sqrt{LC}}\right)^2}$
 b. Second order system of the two poles are $-\frac{R}{2L} \pm \sqrt{\left(\frac{R}{2L}\right)^2 - \left(\frac{1}{\sqrt{LC}}\right)^2}$
 c. Second order system of the poles is $\frac{R}{2L} \sqrt{\left(\frac{R}{2L}\right)^2 - \left(\frac{1}{\sqrt{LC}}\right)^2}$
 d. None of the above

99. For a series resonant circuit at low frequency circuit impedance is _____ and at high frequency circuit impedance is _____. Fill in the blanks respectively

- a. capacitive, inductive b. inductive, capacitive
 c. resistive, inductive d. capacitive, resistive

100. What is the current in the feedback resistor for the circuit given below?

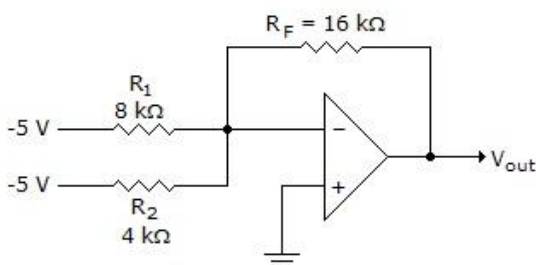

- a. 0.625 mA b. 1.25 mA
 c. 1.875 mA d. 1.625 mA

